



Micro Commercial Components

Micro Commercial Components
 20736 Marilla Street Chatsworth
 CA 91311
 Phone: (818) 701-4933
 Fax: (818) 701-4939

TIP42/42A/42B/42C

Features

- Lead Free Finish/RoHS Compliant(Note 1) ("P" Suffix designates RoHS Compliant. See ordering information)
- The complementary NPN types are the TIP41 respectively
- Case Material: Molded Plastic. UL Flammability Classification Rating 94V-0 and MSL Rating 1
- Marking : Part Number

Silicon PNP Power Transistors

Absolute Maximum Ratings @ T_a = 25°C (unless otherwise noted)

Symbol	Parameter	Value	Unit
V _{CB0} TIP42 TIP42A TIP42B TIP42C	Collector-base voltage (Open emitter)	-40 -60 -80 -100	V
V _{CE0} TIP42 TIP42A TIP42B TIP42C	Collector-emitter voltage (Open base)	-40 -60 -80 -100	V
V _{EBO}	Emitter-base Voltage (Open collector)	-5	V
I _C	Collector Current	-6	A
I _{CM}	Collector Current Pulse	-10	A
I _B	Base Current	-2	A
P _C	Total Device Dissipation(T _a =25°C)	-2	W
	Total Device Dissipation(T _c =25°C)	65	W
T _J	Junction Temperature	150	°C
T _{STG}	Storage Temperature Range	-65 to +150	°C

Electrical Characteristics @ 25°C Unless Otherwise Specified

Symbol	Parameter	Min	Max	Units
V _{CE0(SUS)} TIP42 TIP42A TIP42B TIP42C	Collector-emitter sustaining voltage (I _C =-30mA; I _B =0)	-40 -60 -80 -100		V
V _{CE(sat)}	Collector-emitter Saturation Voltage (I _C =-6A I _B =-0.6A)		-1.5	V
V _{BE}	Base-emitter Voltage (I _C =-6A ; V _{CE} =-4V)		-2.0	V
I _{CES} TIP42 TIP42A TIP42B TIP42C	Collector cut-off current (V _{CE} =-40V; V _{EB} =0) (V _{CE} =-60V; V _{EB} =0) (V _{CE} =-80V; V _{EB} =0) (V _{CE} =-100V; V _{EB} =0)	-0.4		mA
I _{CEO} TIP42/42A TIP42B/C	Collector cut-off current (V _{CE} =-30V; V _{EB} =0) (V _{CE} =-60V; V _{EB} =0)	-0.7		mA
I _{EBO}	Emitter cut-off current (V _{EB} =-5V; I _C =0)		-1.0	mA
h _{fe}	DC current gain (I _C =-0.3A ; V _{CE} =-4V) (I _C =-3A ; V _{CE} =-4V)	30 15	75	
f _T	Transition frequency (I _C =-0.5A ; V _{CE} =-10V)	3		MHZ

Notes:1.High Temperature Solder Exemption Applied, see EU Directive Annex 7.

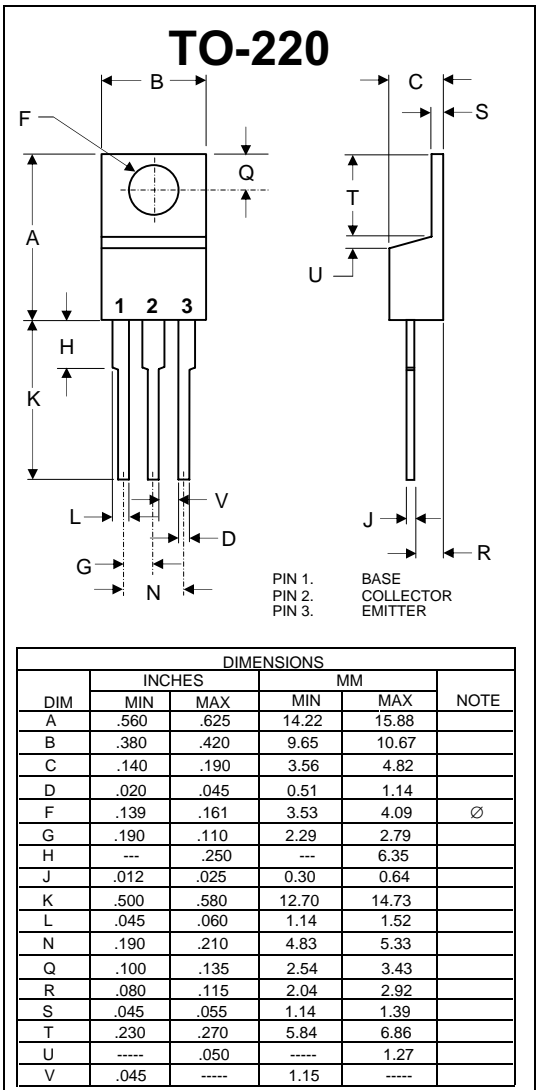



Micro Commercial Components

Ordering Information

Device	Packing
(Part Number)-BP	Bulk; 1Kpcs/Box

IMPORTANT NOTICE

Micro Commercial Components Corp. reserve the right to make changes without further notice to any product herein to make corrections, modifications, enhancements, improvements, or other changes. *Micro Commercial Components Corp.* does not assume any liability arising out of the application or use of any product described herein; neither does it convey any license under its patent rights, nor the rights of others. The user of products in such applications shall assume all risks of such use and will agree to hold *Micro Commercial Components Corp.* and all the companies whose products are represented on our website, harmless against all damages.

APPLICATIONS DISCLAIMER

Products offer by *Micro Commercial Components Corp.* are not intended for use in Medical, Aerospace or Military Applications.